



*Fronius* **KASAMAS** *Speedglas* parweld **SOLTER** *Kjellberg*

# Ádám és Ádám Kft

**HEGESZTÉSTECHNIKA  
FÉMSZÓRÁSTECHNIKA**

Székhely: 4400 Nyíregyháza, Ószőlő út 99.      Telephely: 4400 Nyíregyháza, Rákóczi út 102.  
Tel.: +36 42 504-093, +36 42 504-094, +36 20 9449-003, +36 20 9555-417      Fax.: +36 42 504-095  
E-mail: [info@adam-adam.hu](mailto:info@adam-adam.hu)      Weblap: [www.adam-adam.hu](http://www.adam-adam.hu)      Webshop: [shop.adam-adam.hu](http://shop.adam-adam.hu)

**TTG 2200A**

**TTG 2200A F**

- (D)** Ersatzteilliste  
WIG-Handsweißbrenner
- (GB)** Spare Parts List  
TIG Manual welding torch
- (F)** Liste de pièces de rechange  
chalumeau manuelle TIG
- (I)** Lista parti di ricambio  
cannello di saldatura WIG
- (E)** Lista de repuestos  
Soplete para soldadura manual  
TIG
- (P)** Lista de peças sobresselentes  
Queimador de soldadura MIG

[www.fronius-hegesztogep.com](http://www.fronius-hegesztogep.com)

**Ádám és Ádám Kft**

4400 Nyíregyháza, Rákóczi út 102

Tel.: +36 42 504 093 +36 20 9449 003

4,035,713 TTG2200A F / 4m / 13,1ft  
 4,035,714 TTG2200A F / 8m / 26,2ft  
  
 4,035,709 TTG2200A F / UD / 4m / 13,1ft  
 4,035,712 TTG2200A F / UD / 8m / 26,2ft  
  
 4,035,731 TTG2200A F / JM / Le / 4m / 13,1ft  
 4,035,734 TTG2200A F / JM / Le / 8m / 26,2ft  
  
 4,035,717 TTG2200A F/F / UD / 4m / 13,1ft  
 4,035,718 TTG2200A F/F / UD / 8m / 26,2ft  
  
 4,035,735 TTG2200A F/F / JM / Le / 4m / 13,1ft  
 4,035,741 TTG2200A F/F / JM / Le / 8m / 26,2ft

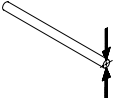
	Ø mm	Ø inch
	1,0-4,0	0,039-0,157



TTG2200A F/UD/JM/Le, TTG2200A F F/JM/Le

Ersatzteilliste / Spare parts list / Listes de pièces de rechange / Lista de repuestos / Lista de peças sobresselentes / Lista dei Ricambi

### STANDARD

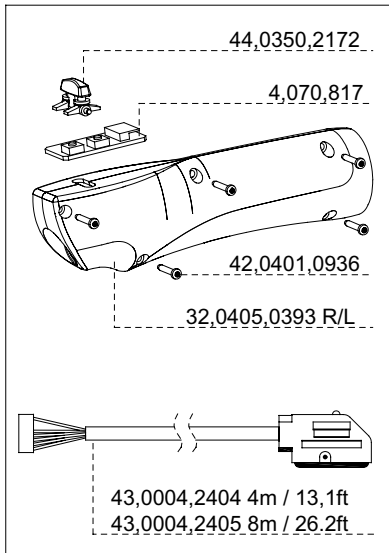

### UP/DOWN

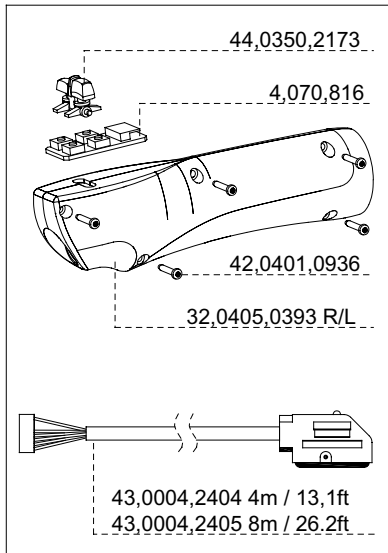

### JOBMASTER

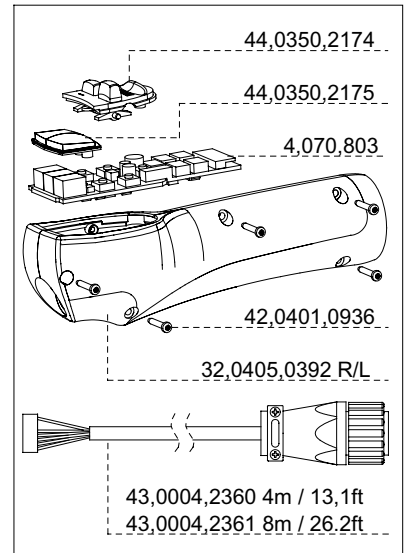

44,0350,2176 4m / 13,1ft / 44,0350,2177 8m / 26,2ft

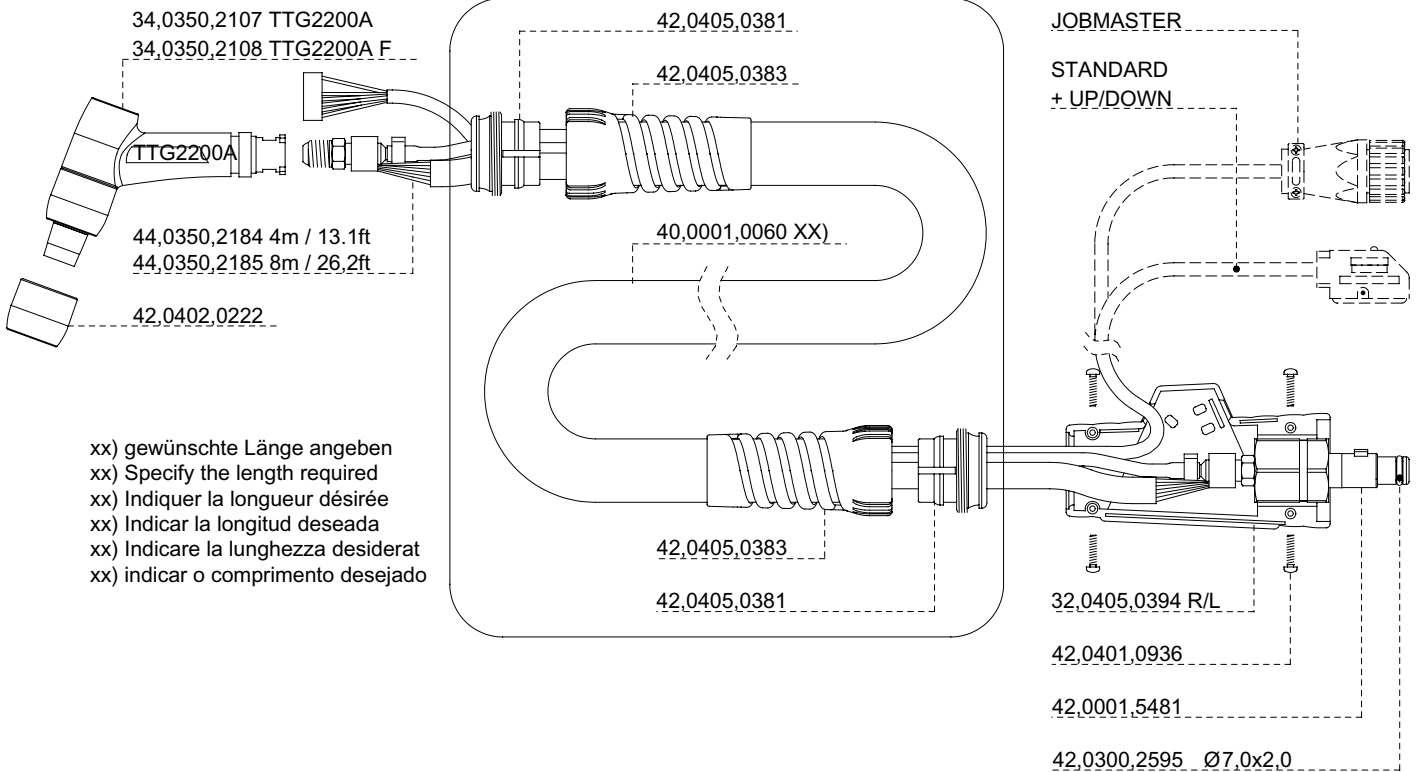

### OPTION - Leder / Leather / Cuir

44,0350,2180 4m / 13,1ft / 44,0350,2181 8m / 26,2ft

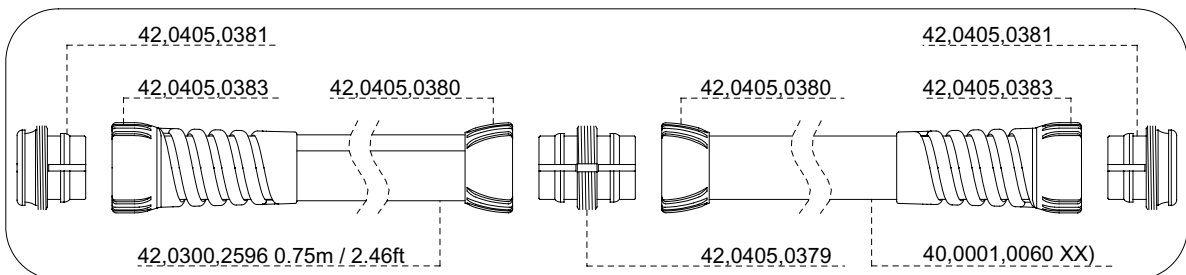

TTG2200A F/UD/JM/Le, TTG2200A F F/JM/Le

Ersatzteilliste / Spare parts list / Listes de pièces de rechange / Lista de repuestos / Lista de peças sobresselentes / Lista dei Ricambi

2/3

Electrode Ø		Part No. gas lens	Part No. clamping nut	Part No. collet	Part No. electrode WC20	Part No. electrode WP
Ø mm	Ø inch					
1,0	.039	44,0350,1500	42,0001,0692	42,0001,0697	42,0411,4012	
1,6	.063	44,0350,1501	42,0001,0693	42,0001,0698	42,0411,4001	42,0411,4008
2,4	.094	44,0350,1460	42,0001,0694 x)	42,0001,0699 x)	42,0411,4002 x)	42,0411,4005
3,2	.126	44,0350,1461	42,0001,0695	42,0001,0700	42,0411,4003	42,0411,4006
4,0	.157		42,0001,0696	42,0001,0701	42,0411,4013	42,0411,4007
4,8	.189				42,0411,4014	42,0411,4009

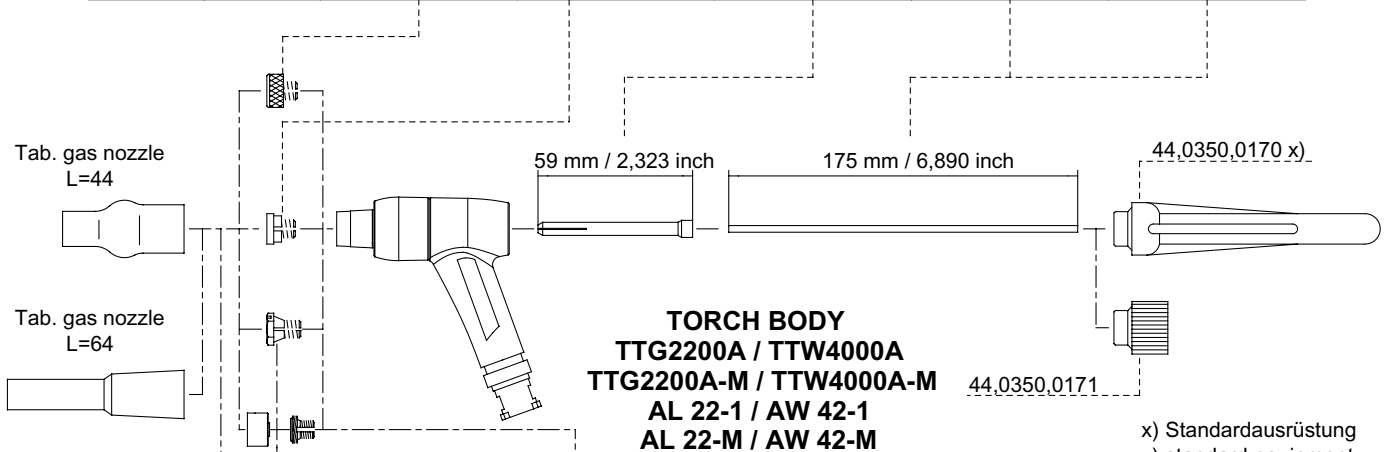

- x) Standardausrüstung
- x) standard equipment
- x) équipement standard
- x) equipamiento estándar
- x) accessori standard
- x) equipamento de série

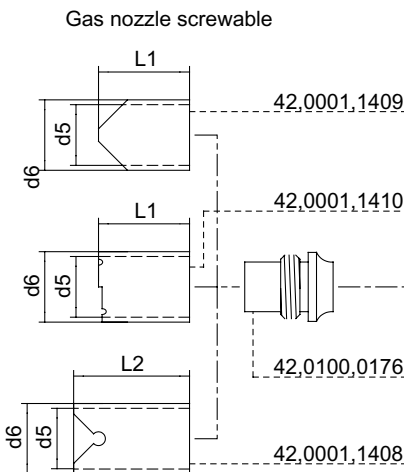

gas nozzle ceramic plugable L=44	d1		d2		Part No.
	mm	inch	mm	inch	
	6,4	.252	21,0	.827	42,0300,0672
	7,9	.3125	21,0	.827	42,0300,0461
	9,5	.374	21,0	.827	42,0300,0462 x)
	11,1	.437	21,0	.827	42,0300,0463
	12,7	.500	21,0	.827	42,0300,0464
	14,3	.563	21,0	.827	42,0300,0465
	15,9	.626	21,0	.827	42,0300,0466
18,0	.709	23,0	.906	42,0300,0467	

TTG 2200 A-M AL 22-M		TTW 4000 A-M AW 42-M	
Electrode Ø		Part No. gas lens	Part No. clamping nut
Ø mm	Ø inch		
1,0	.039		42,0001,1667
1,6	.063		42,0001,1668
2,4	.094		42,0001,1669
3,2	.126		42,0001,1670
4,0	.157		42,0001,1671
4,8	.189		42,0001,1481
2,4	.094	44,0350,1462	42,0001,2741
3,2	.126	44,0350,1463	42,0001,2742

gas nozzle ceramic plugable L=64	d3		d4		Part No.
	mm	inch	mm	inch	
	6,4	.252	17,5	.689	42,0300,1120
	7,9	.3125	17,5	.689	42,0300,1121
	9,5	.374	17,5	.689	42,0300,1122
	11,1	.437	17,5	.689	42,0300,1123

Measurement gas nozzle screwable							
d5		d6		L1		L2	
mm	inch	mm	inch	mm	inch	mm	inch
22	.866	25,5	1,004	33	1,299	42	1,654



TTG2200A F/UD/JM/Le, TTG2200A F/JM/Le

Ersatzteilliste / Spare parts list / Listes de pièces de rechange / Lista de repuestos / Lista de peças sobresselentes / Lista dei Ricambi

[www.fronius-hegesztogep.com](http://www.fronius-hegesztogep.com)

**Ádám és Ádám Kft**

4400 Nyíregyháza, Rákóczi út 102

Tel.: +36 42 504 093 +36 20 9449 003

**FRONIUS INTERNATIONAL GMBH**

Froniusplatz 1, A-4600 Wels, Austria

Tel: +43 (0)7242 241-0, Fax: +43 (0)7242 241-3940